



rudolfstorz[®]

Bohrapparate und Sägen | *Drills and Saws*





1-15-805-10

1 - 6 mm

Universal-Bohrfutter mit T-Griff,
Durchgangsbohrung: Ø5.2 mm

*Universal chuck with T-handle,
through hole: Ø5.2 mm*



1-15-805-20

0.5 - 7 mm

Bohrfutter mit Röhm-Futter und T-Griff, mit Schlüssel (1-20-310-25)
Durchgangsbohrung: Ø6.1 mm

*Chuck with Röhm-chuck and T-handle, with key (1-20-310-25)
through hole: Ø6.1 mm*



1-15-805-21

0 - 4 mm

Bohrfutter mit Jacobs-Futter und T-Griff mit Schlüssel (1-20-310-20)
Durchgangsbohrung: Ø5.2 mm

*Chuck with Jacobs-chuck and T-handle with key (1-20-310-20)
through hole: Ø5.2 mm*



1-15-805-25

1 - 6 mm

Universal-Bohrfutter mit T-Griff und Sicherung
Durchgangsbohrung: Ø6.1 mm

*Universal chuck with T-handle and reverse lock,
through hole: Ø6.1 mm*

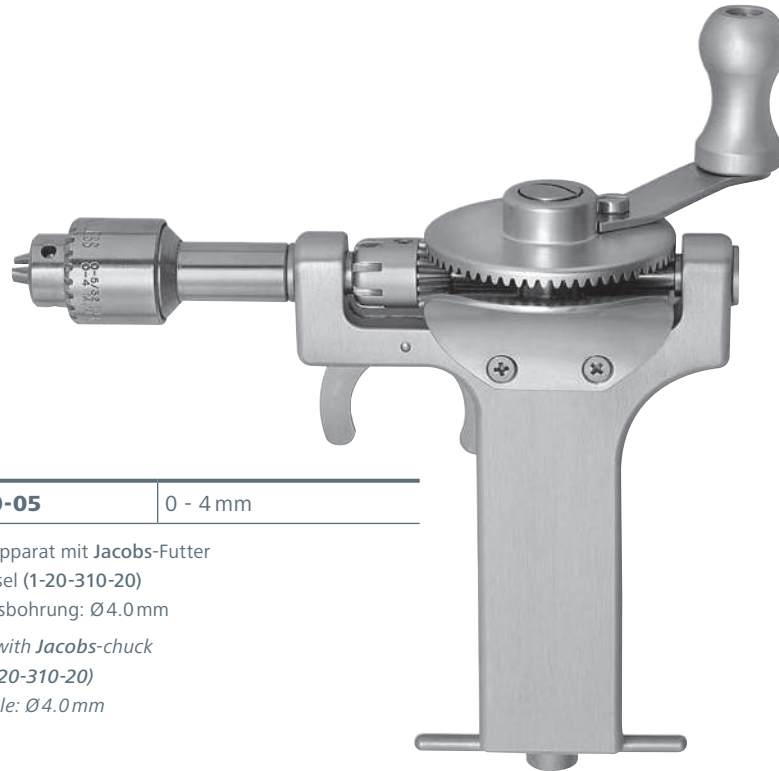
**BUNNEL**

1-20-310-05	0 - 4 mm
--------------------	----------

Handbohrapparat mit Jacobs-Futter
und Schlüssel (1-20-310-20)
Durchgangsbohrung: Ø4.0 mm

*Hand drill with Jacobs-chuck
and key (1-20-310-20)
through hole: Ø4.0 mm*

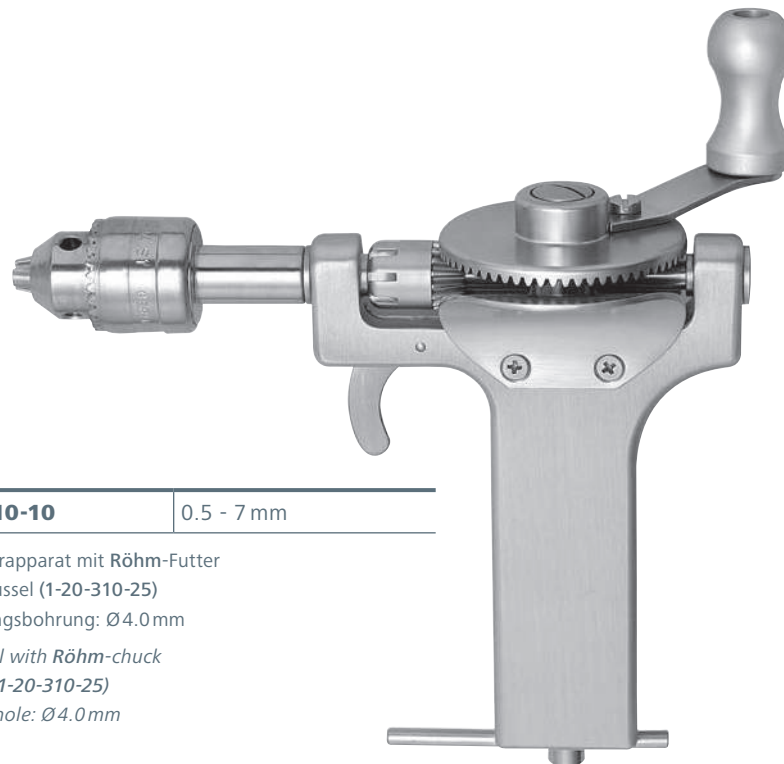
**BUNNEL**

1-20-310-10	0.5 - 7 mm
--------------------	------------

Handbohrapparat mit Röhm-Futter
und Schlüssel (1-20-310-25)
Durchgangsbohrung: Ø4.0 mm

*Hand drill with Röhm-chuck
and key (1-20-310-25)
through hole: Ø4.0 mm*

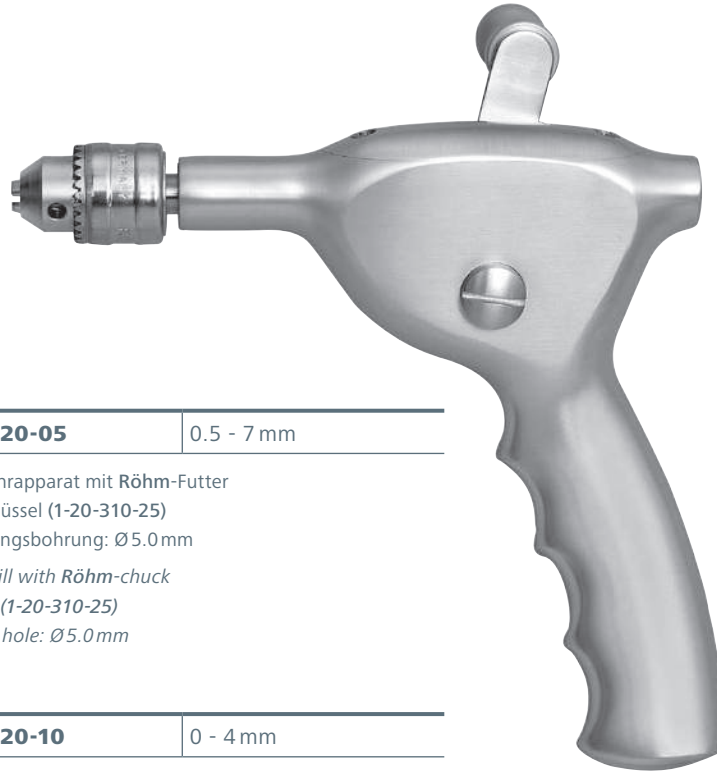

RALK

1-20-320-05	0.5 - 7 mm
--------------------	------------

Handbohrapparat mit Röhm-Futter und Schlüssel (1-20-310-25)
Durchgangsbohrung: Ø5.0 mm

Hand drill with Röhm-chuck and key (1-20-310-25) through hole: Ø5.0 mm

RALK

1-20-320-10	0 - 4 mm
--------------------	----------

Handbohrapparat mit Jacobs-Futter und Schlüssel (1-20-310-20)
Durchgangsbohrung: Ø4.0 mm

Hand drill with Jacobs-chuck and key (1-20-310-20) through hole: Ø4.0 mm

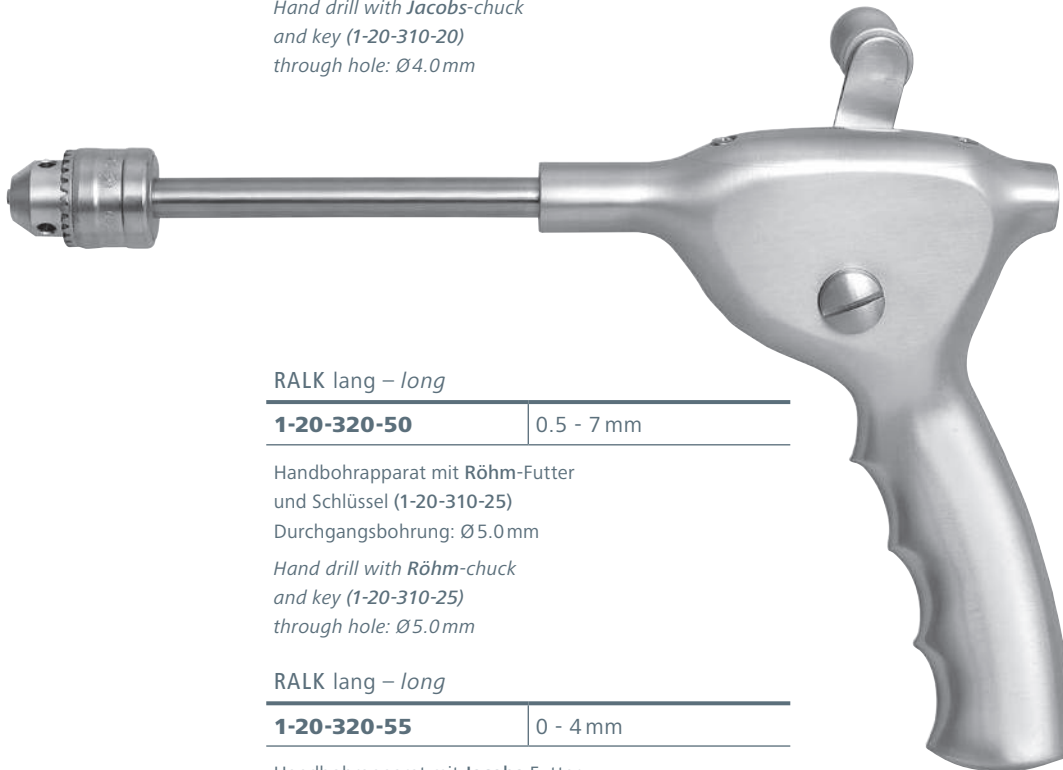

RALK lang – long

1-20-320-50	0.5 - 7 mm
--------------------	------------

Handbohrapparat mit Röhm-Futter und Schlüssel (1-20-310-25)
Durchgangsbohrung: Ø5.0 mm

Hand drill with Röhm-chuck and key (1-20-310-25) through hole: Ø5.0 mm

RALK lang – long

1-20-320-55	0 - 4 mm
--------------------	----------

Handbohrapparat mit Jacobs-Futter und Schlüssel (1-20-310-20)
Durchgangsbohrung: Ø4.0 mm

Hand drill with Jacobs-chuck and key (1-20-310-20) through hole: Ø4.0 mm



GIGLI

1-20-180-05

Handgriff für Drahtsägen, 1 Stück
Hook handle for wire saws, 1 piece



1-20-180-03

Handgriff zur GIGLI Säge mit Schlaufengriff, 1 Stück
Hook handle with loop design for wire saws, 1 piece

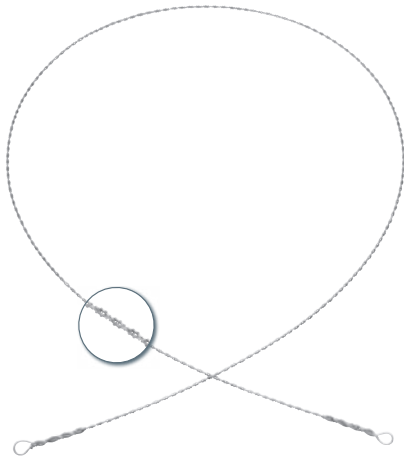

OLIVECRONA / GIGLI

	A	Ø
1-20-155-05	300 mm – 12"	1.20 mm
1-20-155-10	400 mm – 16"	1.20 mm
1-20-155-15	500 mm – 20"	1.20 mm
1-20-155-20	600 mm – 24"	1.20 mm
1-20-155-25	700 mm – 27½"	1.20 mm

Drahtsägen
Wire saws

OLIVECRONA / GIGLI

	A	Ø
1-20-160-05	300 mm – 12"	1.40 mm
1-20-160-10	400 mm – 16"	1.40 mm
1-20-160-15	500 mm – 20"	1.40 mm
1-20-160-20	600 mm – 24"	1.40 mm
1-20-160-25	700 mm – 27½"	1.40 mm

Drahtsägen
Wire saws

1-20-180-10	330 mm
--------------------	--------

Einführungsinstrument für Drahtsägen
Conductor for wire saws

